

**FULL FLOW AND POSITIVE SHUT-OFF  
UP TO 12,000 PSI**

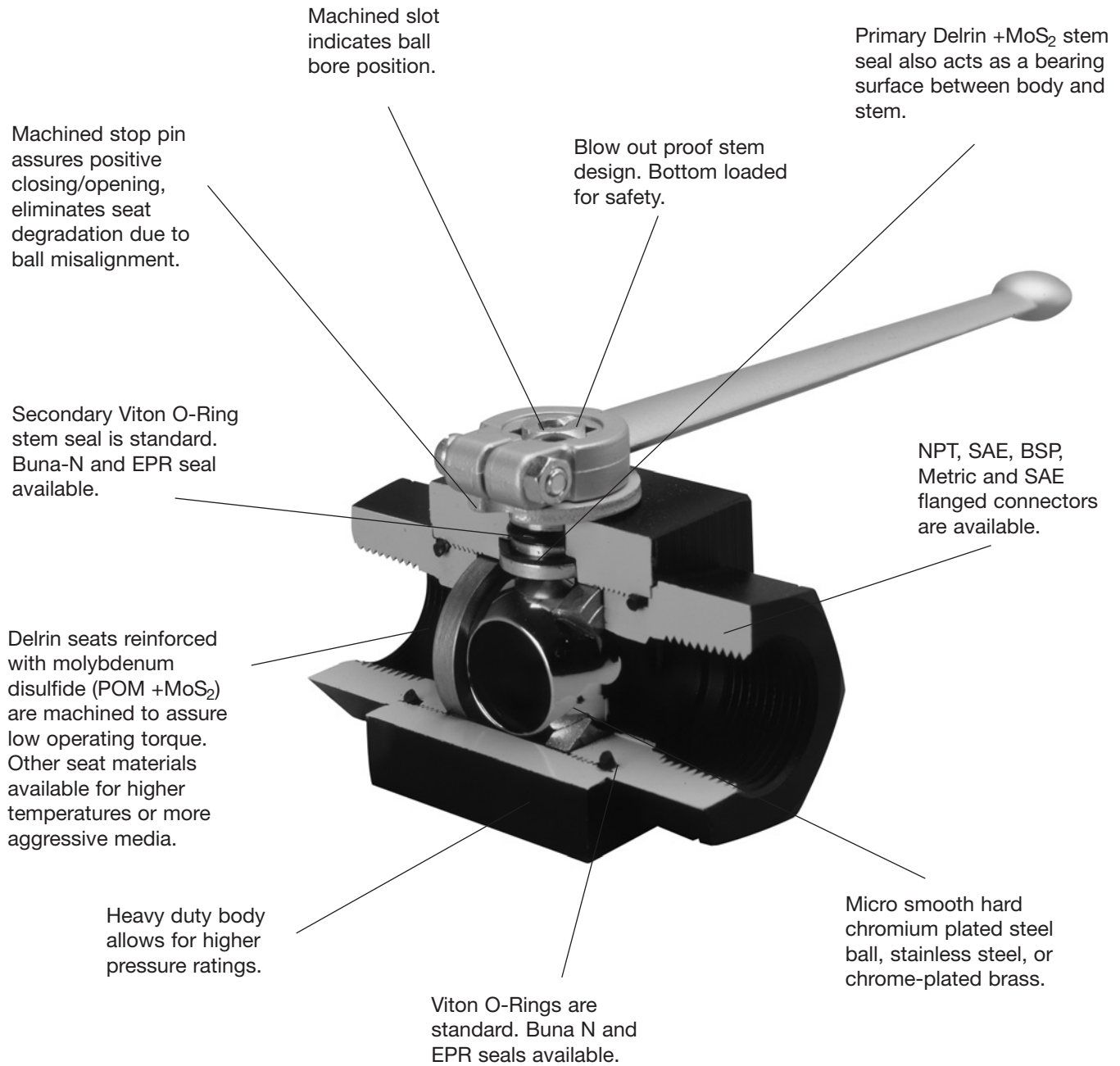

Dimensions are for general information only. Due to constant development and updating of technical details, we ask that all critical dimensions be verified by requesting a certified print.