

Technical Data

STAUFF high pressure filters are designed for in-line hydraulic applications, with a maximum operating pressure of 420 bar (6000 PSI). Used together with STAUFF filter elements, a high efficiency of contaminant removal is assured. The high dirt holding capacity of the elements ensures long service life and, as a result, reduced maintenance costs.

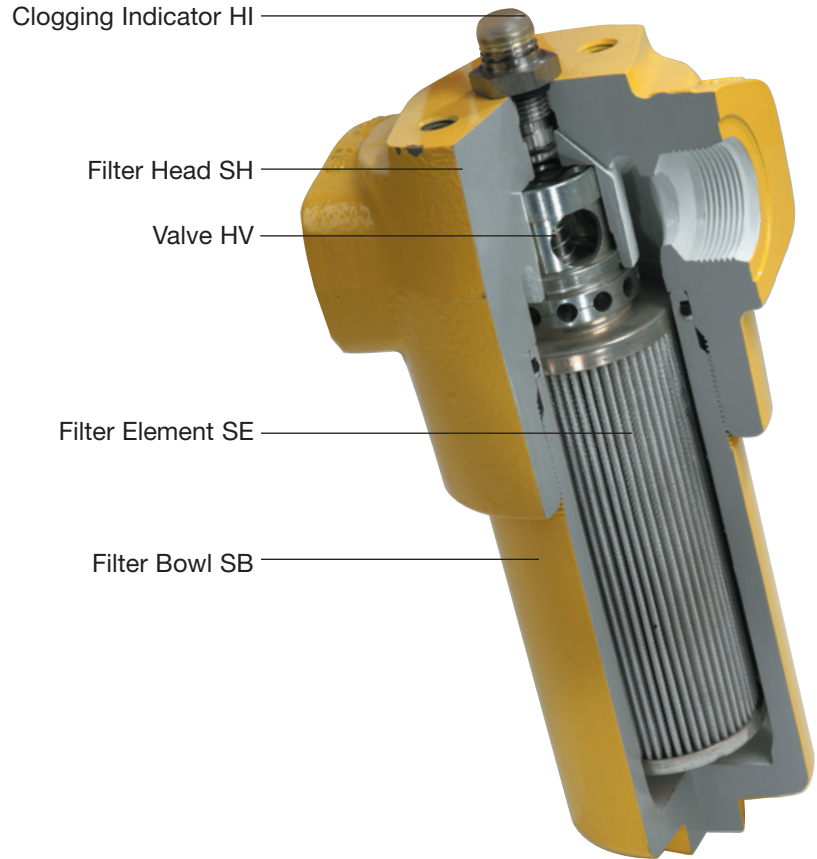

Technical Specification

Construction	In-line assembly, with threaded mounting holes on top of head
Filter head	Spheroidal graphite cast iron
Filter bowl	Cold drawn steel
Seals	O-Rings NBR (Buna-N®) FPM (Viton®) EPDM (Ethylene-propylene), support ring PTFE
Port connections	BSP, NPT, SAE "O"-Ring thread or SAE Code 61 & 62 flange
Operating pressure	max 420 bar (6000 PSI)
Proof pressure	630 bar (9100 PSI)
Burst pressure	>1260 bar (18250 PSI)
Temperature range	-10°C up to +100°C (14°F up to 212°F)
By-pass valve	Allows unfiltered oil to by-pass the contaminated element once the opening pressure has been reached, 6 + 0,5 bar (87 + 7,25 PSI) Δp is the standard setting. Other settings available upon request.

Reverse flow valve	Allows reverse flow through the filter head without backflushing the element
Non-return valve	Prevents draining of the delivery line during element change
Multi-function valve	Forward by-pass, reverse flow capability, and non return valve opening pressure 6 +0,5 bar (87 +7,25 PSI) Δp all in one valve
Clogging indicators	standard actuating pressure 5 +0,5 bar (72 -7,25 PSI) Δp Available indicators: visual, electrical and visual-electrical (24 V, 110 V, 220 V versions) other actuating pressures are available upon request
Filter elements	Specifications see page F10-12
Media	Mineral oils, other fluids on request