

1. Visual Clogging Indicator

Part number HIR-V is a clogging indicator actuated by the differential pressure across the filter element. The actuating pressure of 2.4 bar (35 psi) allows the dirty element to be changed before the by-pass setting of 3.4 bar (50 psi) is reached.

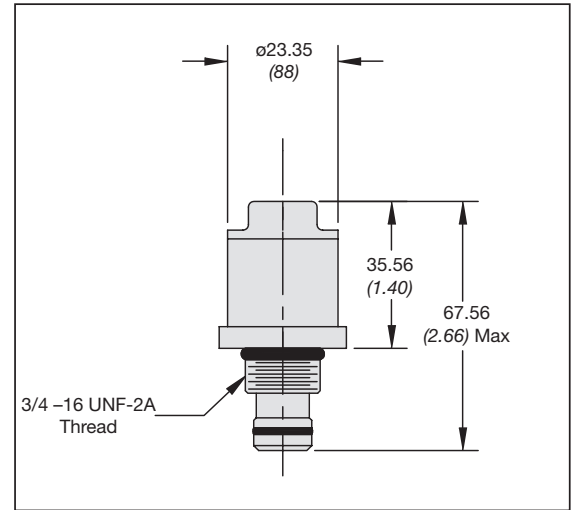

2. Visual / Electrical clogging indicator

Part number HIR-VE is used when an electrical signal is needed to indicate when the element needs changing. It is actuated by the differential pressure across the filter element. The actuating pressure of 2.4 bar (35 psi) allows the dirty element to be changed before the by-pass setting of 3.4 bar (50 psi) is reached.

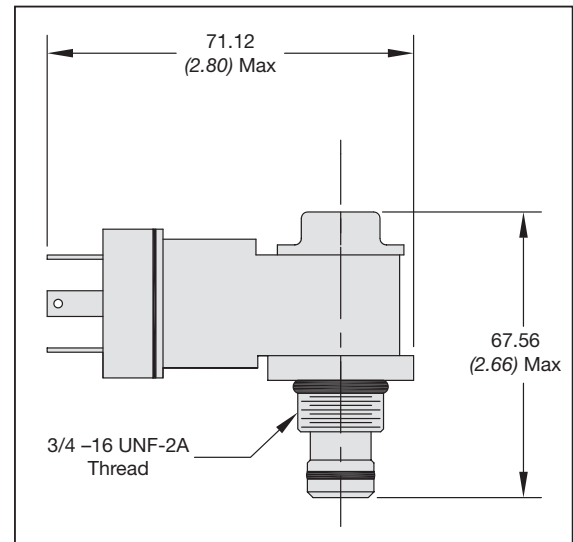

HIR-VE Rated capacity

4 amps inductive,
7 amps, resistive, 28 vdc.
7 amps, 250 vac.

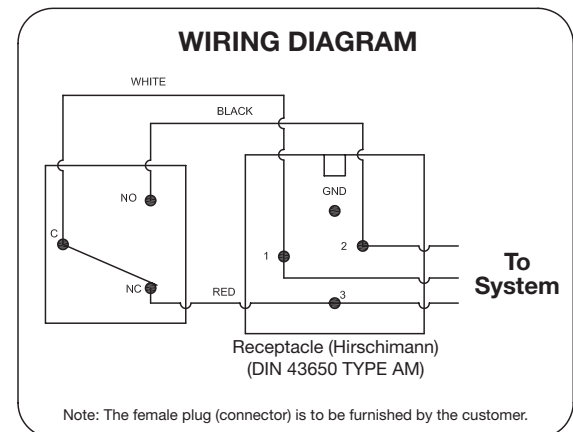
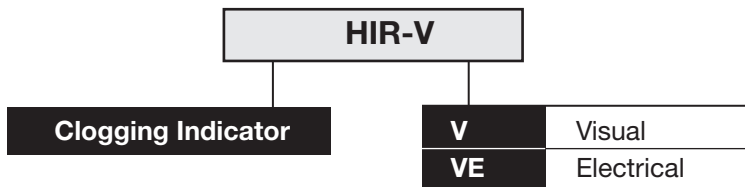

INSTALLATION:
Lubricate both O-Rings supplied with the indicator.
Install in the cavity & torque to 30-35 ft-lbs (41-47 NM)

FILTRATION