

Technical Data

Stauff RFA return line filters are a one piece design and can be used as a tank top or an inline filter. They are mounted in the return line and if 100% of the system oil is filtered, provide the optimum removal of contaminant for the systems. This provides the pump with clean oil, thus reducing contaminant generated wear.



Technical Specification

Construction	Tank Top flange or in line mounting
Filter head/bowl	Aluminium
Seals	NBR (Buna-N®), FPM (Viton®) or EPDM (Ethylene-Propylene)
Threaded connection	SAE-"O"-Ring thread
Operating pressure	max 25 bar (365 PSI)
Proof pressure	37.5 bar (545 PSI)
Temperature range	-10° to +100°C (14° to 212°F)

By-pass valve (integrated in the filter element)	Opening pressure 3 bar ± 0,3 bar (43.5 PSI ± 4.35 PSI) other pressures on request
Clogging indicator	Gauge type indicator 0...4 bar (0...58 PSI) colored segments; Electrical switch, setting 2.5 bar (36.25 PSI)
Filter elements	Specification see page F57
Media	Mineral oils, other fluids on request

Dimensions

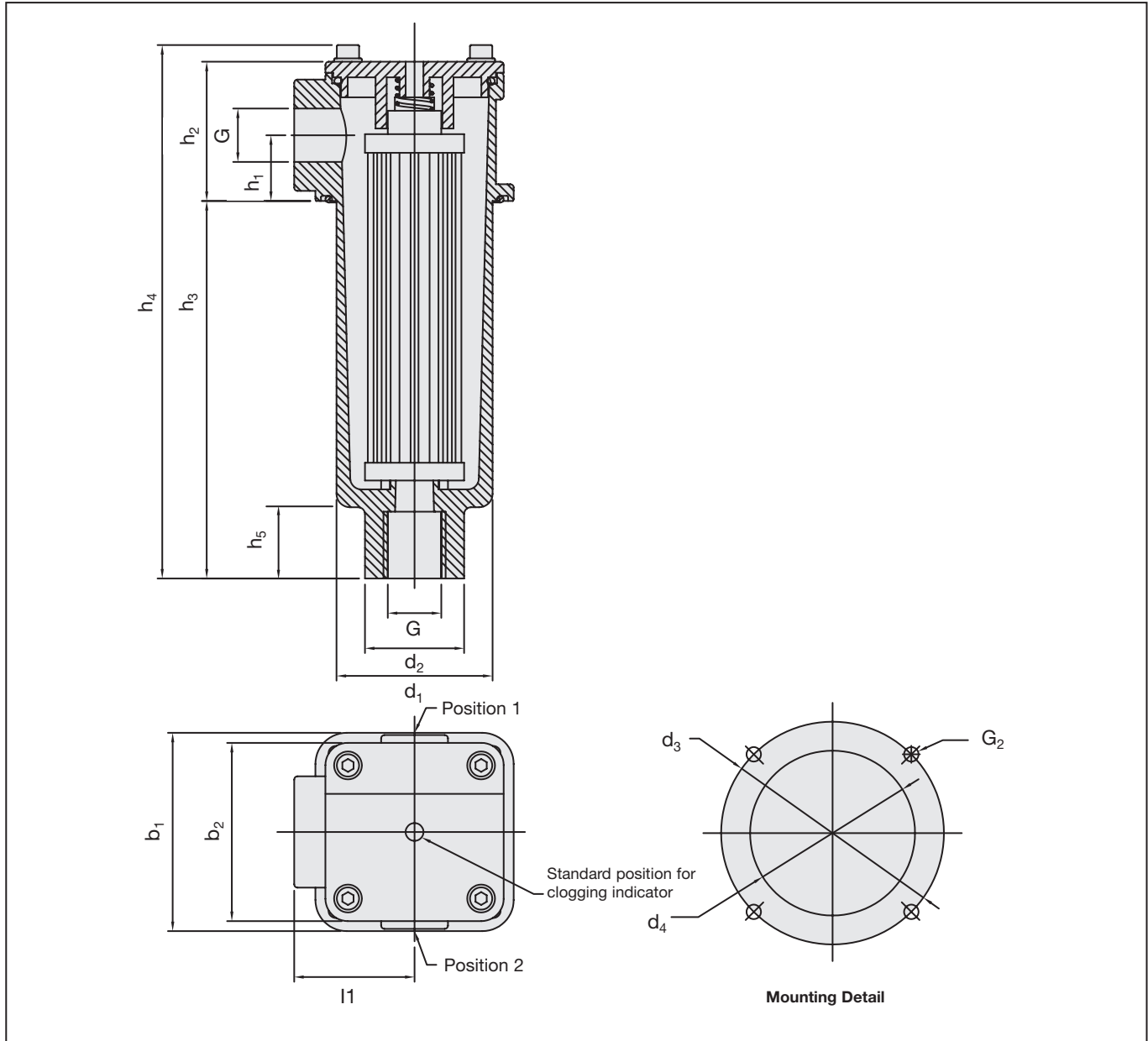

FILTRATION

Dimensions RFA030 Filters

Dimensions in mm (inch)

Filter Size	Thread Connection G SAE-"O" Ring Thread	Dimensions												
		h_1	h_2	h_3	h_4	h_5	b_1	b_2	d_1	d_2	d_3	d_4	l_1	G_2
RFA 030	3/4-16-UN	25.5	62.5	169.5	239.5	32	89	80	70	44.5	100	74	54	M6 or 1/4" UNC
	1-1/16-UN	(1.16)	(2.46)	(6.67)	(9.43)	(1.26)	(3.50)	(3.15)	(2.76)	(1.75)	(3.94)	(2.91)	(2.16)	

Options RFA030

1. Visual clogging indicator HI-M

The gauge visually displays the degree of contamination of the element. The colored segments allow quick visual checking.

green	0...2,5	bar (0...36,25 PSI)	Element has service life left
yellow	2,5...3,0	bar (36,25 ...43,5 PSI)	Element is contaminated and should be changed
red	>3,0	bar (>43,5 PSI)	By-pass valve open, unfiltered oil passing to tank

2. Electrical clogging switch HI-G

The switch is used where an electrical signal is needed to indicate when the element needs changing. The switch can turn on a light, or shut the machine down, or any further function controlled by an electric signal. The switching pressure is 2,5 bar (36,25 PSI) and this allows the element to be changed before the by-pass setting of 3 bar (43,5 PSI) is reached.

Maximum Voltage	Switch Type
42 V	G 42
110 V	G 110
220 V	G 220

3. Filter bowl with threaded connection (standard)

Under some circumstances such as a tall reservoir or one with oil levels which vary greatly during operation, it is necessary to extend the filter bowl so that the returning oil returns beneath the surface and does not entrain air in the process. The standard bowl with a female thread allows an extension to be fitted quite simply. The one piece design also allows for inline applications.

4. Leakage oil connection

Seal or case drain lines can be connected to the filter through either of the clogging indicator ports providing that the leakage oil can accept a pressure of 3 bar (43.5 PSI). It ensures that no un-filtered oil can return to the reservoir. It may save the cost of a manifold.

5. Filter bowl with threaded connection and diffuser

Diffusers mounted to the filter bowl minimize foaming and reduce noise of high return line flows. For further details on STAUFF diffusers please refer to the "Hydraulic Accessories" section of this catalog.

Dimensions in mm (inch)

Size SRV	for Return Line Filter Size	Dimensions			
		ø D	L	Thread G	SW
SRV-114-B16	RF 014/030	60 (2.36)	139 (5.47)	G 1 or 1" NPT	46 (1.81)

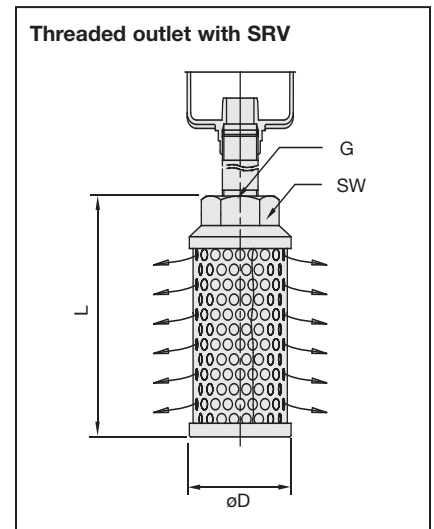
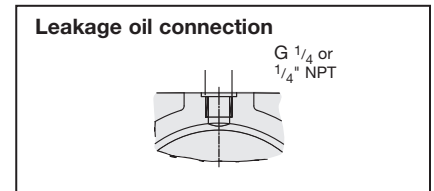
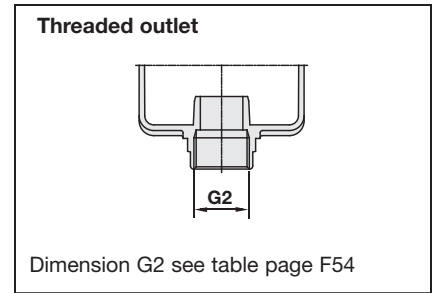
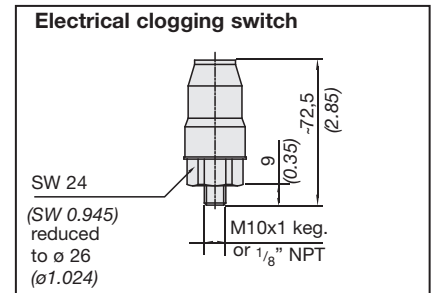
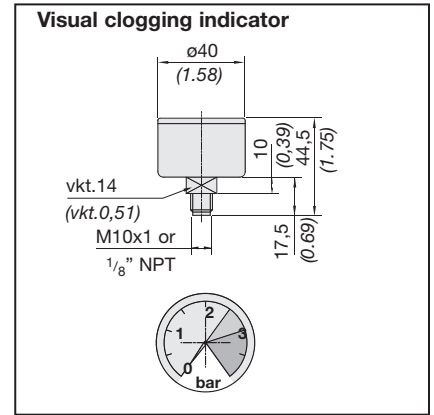

Ordering Code Filter Housings

RFA 030 ... B / U / M / G / L1 / X

Filter Type	RFA	
Group		
Size	Flow	
	l/min	GPM
030	110	30
* Note Exact flow will depend on filter element selected. Consult technical data on page F57		

For Complete Filters:
identification filter material + micron rating code
(see ordering code filter elements below)

Seal Material	
B	NBR (Buna-N®)
V	FPM (Viton®)
E	EPDM
other seal material on request	

Design Code
only for information

Additional Features		Pos*	
L	Leakage Oil Connection	1	2
*Position of leakage oil connection (see page F54) Without any code: assembly in the middle of the filter cover			

Outlet Style	
O	without thread
G	with thread (same as inlet) (standard)

Clogging Indicator		Pos*	
M	Pressure gauge	1	2
G42	Electrical switch 42 V		
G110	Electrical switch 110 V		
G220	Electrical switch 220 V	*Position of clogging indicator (see page F54) Without any code: assembly in the middle of the filter cover	

Connection Style		
Code	Connection style	Thread
U	SAE-"O"-Ring thread	1-1/16-12 UN
U 1	SAE-"O"-Ring thread	3/4-16 UN

Ordering Code Filter Elements

RE-030 G 10 B /X

Series	RE
Group according to filter housing	

Filter Material			Micron ratings available
Code	Material	max Δp^* collapse	
A	Stainless fiber	30 bar (435 PSI)	03, 05, 10, 20
N	Filter paper	16 bar (232 PSI)	
G	Inorganic glass fiber	30 bar (435 PSI)	
S	Stainless mesh	30 bar (435 PSI)	10, 25, 50, 100, 200, 500
*collapse / burst resistance as per ISO 2941			

Design Code
only for information

Seal Material	
B	NBR (Buna-N®)
V	FPM (Viton®)
E	EPDM
other seal materials on request	

Micron Rating	
03	3 μ m
05	5 μ m
10	10 μ m
20	20 μ m
10	10 μ m
25	25 μ m
50	50 μ m
100	100 μ m
200	200 μ m
500	500 μ m
other micron ratings on request	

FILTRATION

Flow Characteristics of Return-line Filters RFA030

The following characteristics are valid for mineral oils with a density of 0,85 kg/dm³ and the kinematic viscosity of 30 mm²/s. The characteristics have been determined in accordance to ISO 3968.

