

BY-PASS Filter BPS Hydraulic Symbol

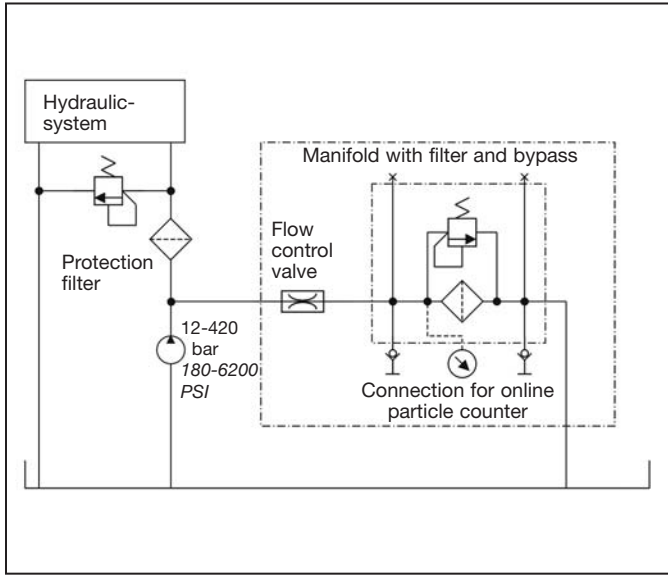

OFF-LINE Filter OLS Hydraulic Symbol

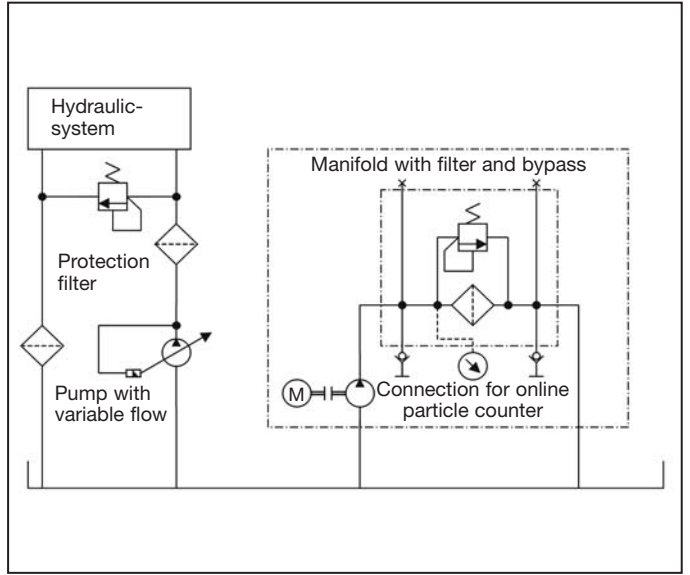

Filter element SRM-30HB Δp / viscosity - graph
(at a flow of 2.1 l/min (0.6 US GPM) per element)

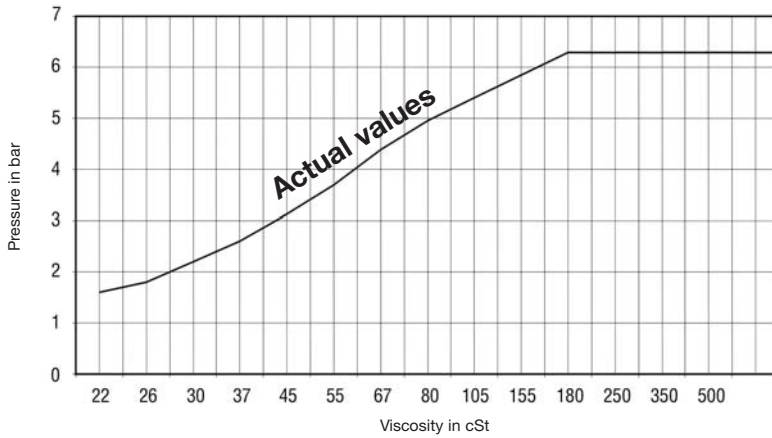

Flow characteristics BY-PASS Filter BPS with filter element SRM-30HB (at maximum viscosity)

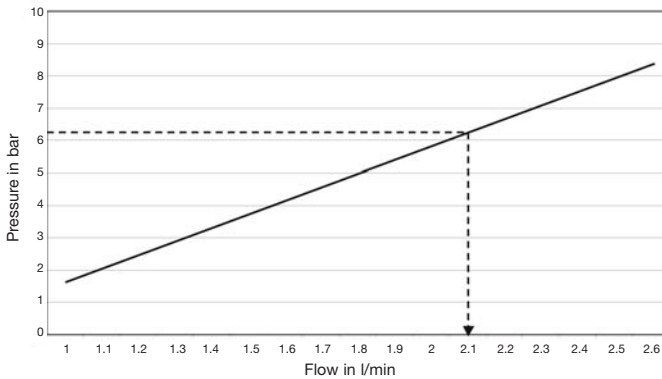

Flow characteristics OFF-LINE Filter OLS with filter element SRM-30HB (at maximum viscosity)

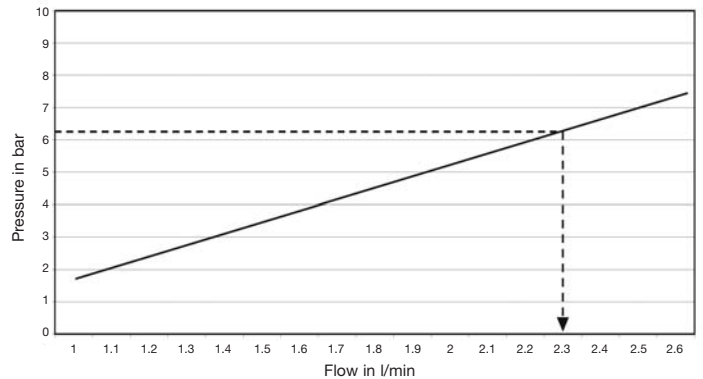

FILTRATION