

Software (optional)

The standard software allows the download and the visualization of the measured particle distribution. Upon request a special software is available that allows the customer to control, monitor and analyze

more than one LPM which are connected in a network. For custom configuration, please contact your local STAUFF partner.

Ordering Code

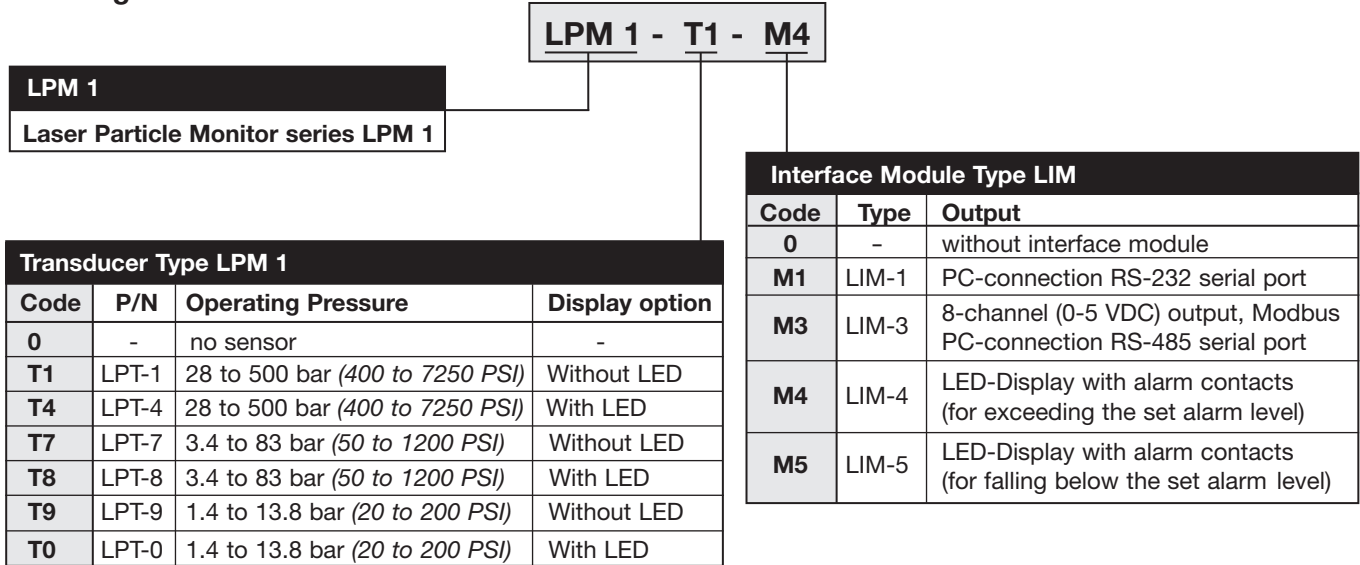

Each LPM 1-Kit includes:

- 1 x LPT Laser Particle Transducer
- 1 x LIM Interface Module
 - LIM-1, includes 6 m (20ft) interconnecting fiber optic cable
 - LIM-3, includes 6 m (20ft) interconnecting fiber optic cable and one breakout cable with 15 pin connector
 - LIM-4, includes 6 m (20ft) interconnecting fiber optic cable, one 3 m (10ft) power cable, and one 3 m (10ft) connection cable for output signal
 - LIM-5, includes 6 m (20ft) interconnecting fiber optic cable, one 3 m (10ft) power cable, and one 3 m (10ft) connection cable for output signal
- 1 x Quick Start Guide
- 1 x Operators Manual
- 1 x Software
 - Includes DDE server
 - Hex and terminal logger for RS-232
 - PDA Shareware

DAV - Dynamic Application Valve

The DAV option is for applications where there is a continuous change of flow or pressure leading up to the LPT. The DAV stabilizes the fluid flow and pressure so that the LPT can read consistent sample volumes.

Example Part Number: LPM1-T7-0-DAV

Each DAV includes:

- 1 x LPMFC-0.2-3/8BSP
- 1 x Thread adaptors for connection of LPT to LPMFC

