

Description

The STAUFF Laser Particle Monitor System LPM 1 is a laser based 4-channel inline particle monitor designed for the continuous monitoring of particle contamination. The LPM 1 provides cumulative particle concentration information at $>4 \mu\text{m}(c)$, $>6 \mu\text{m}(c)$ and $>14 \mu\text{m}(c)$ sizes applicable to the ISO 4406, ISO 11943 and ISO 11171 requirements for optical particle counters. A $> 21 \mu\text{m}(c)$ channel is also provided for larger particle concentration information. Machine operators are alerted to changes in particle contamination levels in a

machine's fluid by the indications provided from the LPM 1. The contamination level will be shown on the display or can be transmitted via the RS-232 serial port into a personal computer. With the ModBus-serial port the data can be transferred into a computer network or to an external display. The LPT particle transducer is configured via the IR-port on a Palm or Pocket Computer. The LPM 1 system consists of a Laser Particle Transducer LPT and a Laser Interface Module LIM (see functional diagram).



Functional diagram

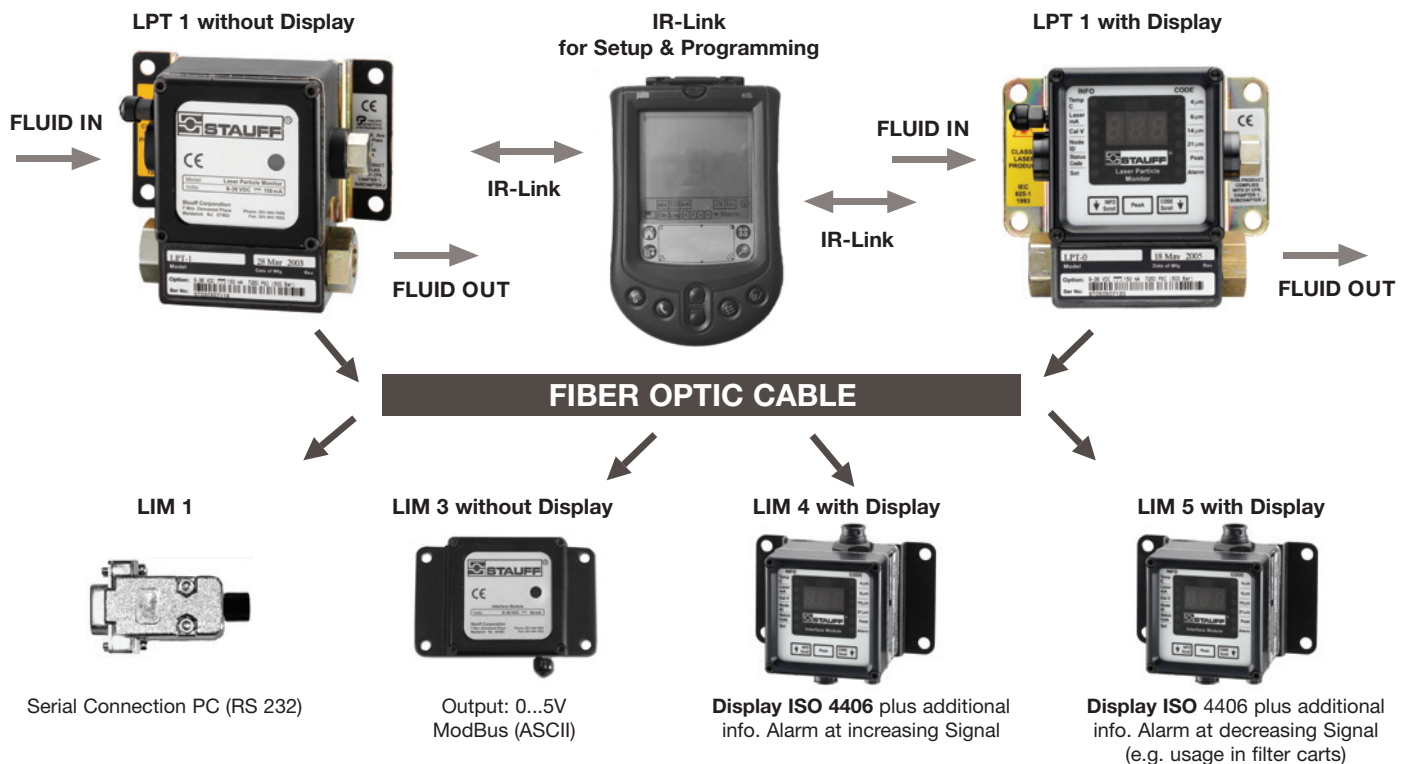

Technical Specification

Channel Sizes	4, 6, 14 and 21 $\mu\text{m}_{(c)}$ (ISO MTD/ISO 11171)	Connections	SAE – 4 (7/16-20 UNF)
Light Source	Laser Diode	Flow Rate	50 to 500 ml/min through the viewing area. All units offer integrated flow rate monitoring with alarms.
Verification	Optional certification available	Fluid Compatibility	Mineral based hydraulic and lubrication oils. Phosphate Esters optional
Sampling	Online continuous monitoring	Viscosity	2 cSt (32 SUS) minimum
Reproducibility	± 0.5 ISO code (ISO 4406)	Operating Pressure	1.4 to 500 bar (20 to 7250 PSI)
Display	Optional local display presents ISO codes and alarms	Operation Temperature	-20 to 60 °C (-4 to 140°F) ambient, -20 to 85 °C (-4 to 185°F) fluid
Power Supply	9 to 36 volts DC	IP	Rating 67
Output	RS-232, RS-485, 0 to 5 volts, Modbus, alarm contacts, local display	Accessories Included	DDE Software, 6m (20 ft.) fiber optic cable, operators manual
Reports	Particles/ml, ISO 4406 codes 4, 6, 14 and additional 21 $\mu\text{m}_{(c)}$ (ISO MTD/ISO 11171)		

Dimensions

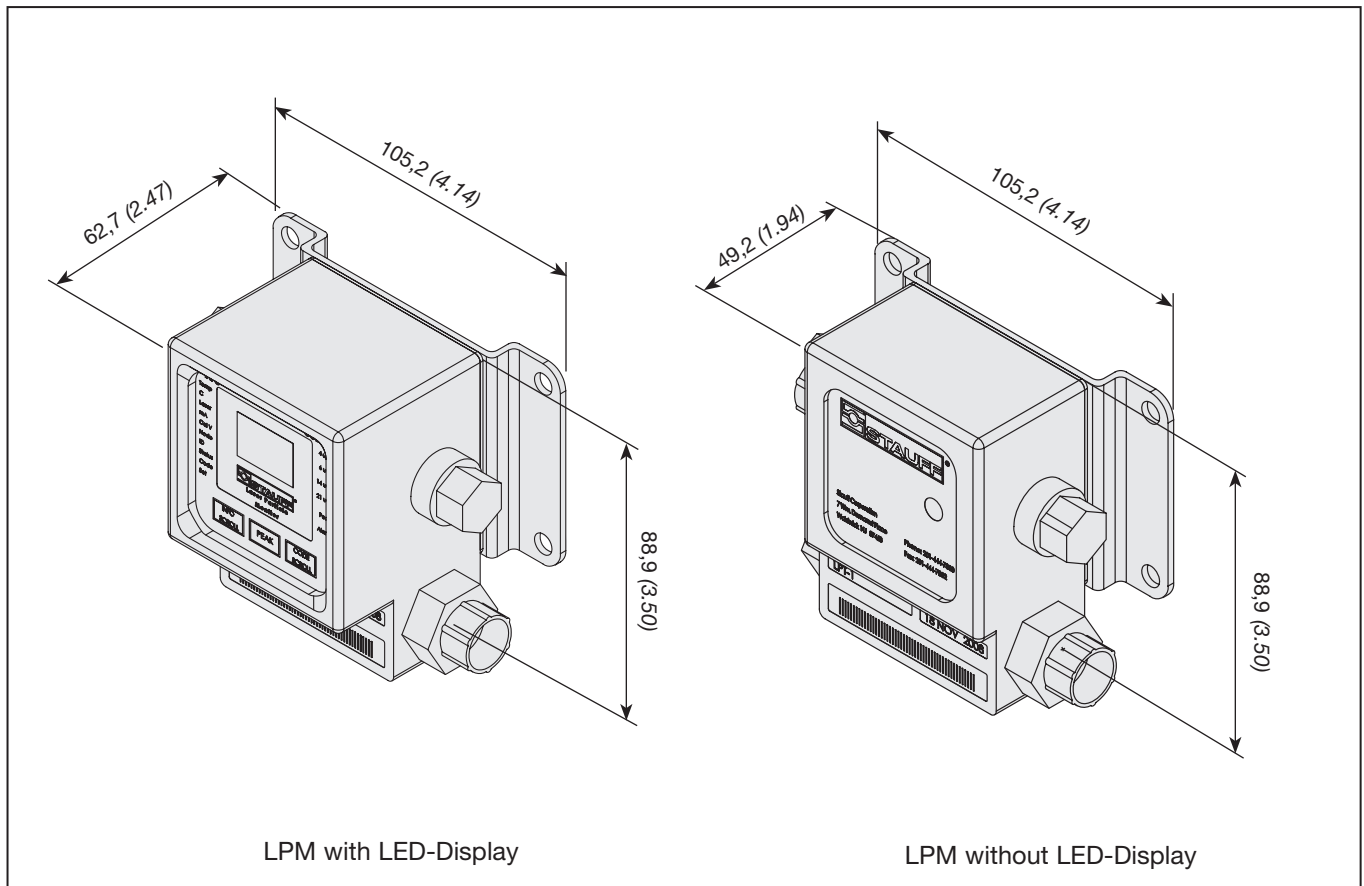

All dimensions in mm (inch)

Description

The LPM 1 system consists of two parts: a LPT Particle Transducer and a LIM Interface module.

Laser Particle Transducer LPT

The LPT Particle transducer contains the sensing device and electronics for detecting the level of contamination.

The laser based sensor uses light blocking technology for particle detection whereby particles passing through an optical flow cell block an amount of laser light proportional to the particle size.

The resultant particle concentration data from the LPT are sent to the LIM interface module via a fiber optic cable. The configuration of the LPT has to be done through the IrDA port of any PDA with IRA capabilities.



The LPT Particle transducers have a flow inhibitor downstream of the sensor that restricts and controls fluid flow from variable pressure sources.

The pressure is reduced to near atmospheric for return to the hydraulic reservoir. The inlet pressure ranges from 1.4 to 500 bar (20 to 7250 PSI) in three models are listed below.

The LPT's are available with or without a LED display. The three digit display shows the selected ISO code value or other function parameters.

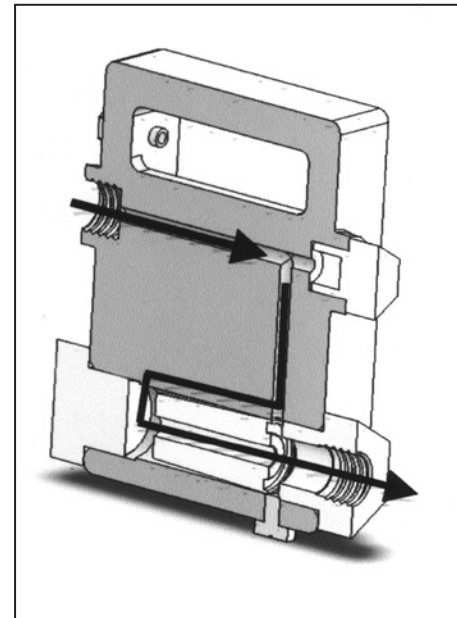

Flow Pattern

Available types of LPT

LPT-1	28 to 500 bar (400 to 7250 PSI), without LED-display
LPT-4	28 to 500 bar (400 to 7250 PSI), with LED-display
LPT-7	3.4 to 83 bar (50 to 1200 PSI), without LED-display
LPT-8	3.4 to 83 bar (50 to 1200 PSI), with LED-display
LPT-9	1.4 to 13.8 bar (20 to 200 PSI), without LED-display
LPT-0	1.4 to 13.8 bar (20 to 200 PSI), with LED-display

Interface Module LIM

The LIM interface module converts the raw count data from the LPT for display or use in acquisition, logging or control systems. A terminal emulation program can be used to read the ASCII data

string. The LIM interface modules are available in four types to meet a wide variety of applications. The LPT is connected to the LIM via a fiber optic cable with a length up to 50 meters (175 ft.).

LIM-1

The LIM-1 interface module has a DCE configuration (9-pin female) for attachment directly to a computer's RS-232 serial port. Power for the LIM-1 is supplied by the computer serial port.

The LIM-1 receives the raw serial data from the LPT transducer via a fiber optic cable and transmits them directly to the computer.



LIM-3

The LIM-3 receives raw serial data input from the LPT transducer via a fiber optic cable. This data string is analyzed and converted into 0 to +5 VDC analog output voltages proportional to the ISO codes and also into ModBus ASCII device protocol for interface to a PLC or computer via RS-485 and RS-232 serial port.

Special adaptors also allow the integration into an ethernet-computer network.

All signal outputs, as well as the input supply voltage (9 to 36 VDC), are connected to the LIM-3 through a DB-15 connector.



LIM-4 and LIM-5

The LIM-4 and LIM-5 receive the raw serial data input from the LPT transducer via a fiber optic cable. Results are displayed on the front panel 3-digit LED display.

The ISO 4406 code number displayed is categorized in four size channels (>4, >6, >14 and >21 $\mu\text{m}(c)$). The ISO number represents the number of particles counts per ml fluid. The user also can select internal information about the transducer (Temperature C, laser mA, Cal V, Node ID status code).

Alarm levels can be programmed for any of the four particle size channels. When set, an alarm indicator will flash if the alarm level is reached. For the LIM-4 the alarm is activated if the measured ISO numbers exceed the set alarm level and for the LIM-5 the alarm is activated if the ISO number falls below the set level.

Alarms on the LIM-4 and LIM-5 may be deactivated by pressing any button. Supply voltage is external and can be from a 9 to 36 VDC source.



Software (optional)

The standard software allows the download and the visualization of the measured particle distribution. Upon request a special software is available that allows the customer to control, monitor and analyze

more than one LPM which are connected in a network. For custom configuration, please contact your local STAUFF partner.

Ordering Code

LPM 1 - T1 - M4

LPM 1
Laser Particle Monitor series LPM 1

Transducer Type LPM 1			
Code	P/N	Operating Pressure	Display option
0	-	no sensor	-
T1	LPT-1	28 to 500 bar (400 to 7250 PSI)	Without LED
T4	LPT-4	28 to 500 bar (400 to 7250 PSI)	With LED
T7	LPT-7	3.4 to 83 bar (50 to 1200 PSI)	Without LED
T8	LPT-8	3.4 to 83 bar (50 to 1200 PSI)	With LED
T9	LPT-9	1.4 to 13.8 bar (20 to 200 PSI)	Without LED
T0	LPT-0	1.4 to 13.8 bar (20 to 200 PSI)	With LED

Interface Module Type LIM		
Code	Type	Output
0	-	without interface module
M1	LIM-1	PC-connection RS-232 serial port
M3	LIM-3	8-channel (0-5 VDC) output, Modbus PC-connection RS-485 serial port
M4	LIM-4	LED-Display with alarm contacts (for exceeding the set alarm level)
M5	LIM-5	LED-Display with alarm contacts (for falling below the set alarm level)

Each LPM 1-Kit includes:

- 1 x LPT Laser Particle Transducer
- 1 x LIM Interface Module
 - LIM-1, includes 6 m (20ft) interconnecting fiber optic cable
 - LIM-3, includes 6 m (20ft) interconnecting fiber optic cable and one breakout cable with 15 pin connector
 - LIM-4, includes 6 m (20ft) interconnecting fiber optic cable, one 3 m (10ft) power cable, and one 3 m (10ft) connection cable for output signal
 - LIM-5, includes 6 m (20ft) interconnecting fiber optic cable, one 3 m (10ft) power cable, and one 3 m (10ft) connection cable for output signal
- 1 x Quick Start Guide
- 1 x Operators Manual
- 1 x Software
 - Includes DDE server
 - Hex and terminal logger for RS-232
 - PDA Shareware

DAV - Dynamic Application Valve

The DAV option is for applications where there is a continuous change of flow or pressure leading up to the LPT. The DAV stabilizes the fluid flow and pressure so that the LPT can read consistent sample volumes.

Example Part Number: LPM1-T7-0-DAV

Each DAV includes:

- 1 x LPMFC-0.2-3/8BSP
- 1 x Thread adaptors for connection of LPT to LPMFC

