

## Description

The LPM 1 system consists of two parts: a LPT Particle Transducer and a LIM Interface module.

### Laser Particle Transducer LPT

The LPT Particle transducer contains the sensing device and electronics for detecting the level of contamination.

The laser based sensor uses light blocking technology for particle detection whereby particles passing through an optical flow cell block an amount of laser light proportional to the particle size.

The resultant particle concentration data from the LPT are sent to the LIM interface module via a fiber optic cable. The configuration of the LPT has to be done through the IrDA port of any PDA with IRA capabilities.



The LPT Particle transducers have a flow inhibitor downstream of the sensor that restricts and controls fluid flow from variable pressure sources.

The pressure is reduced to near atmospheric for return to the hydraulic reservoir. The inlet pressure ranges from 1.4 to 500 bar (20 to 7250 PSI) in three models are listed below.

The LPT's are available with or without a LED display. The three digit display shows the selected ISO code value or other function parameters.

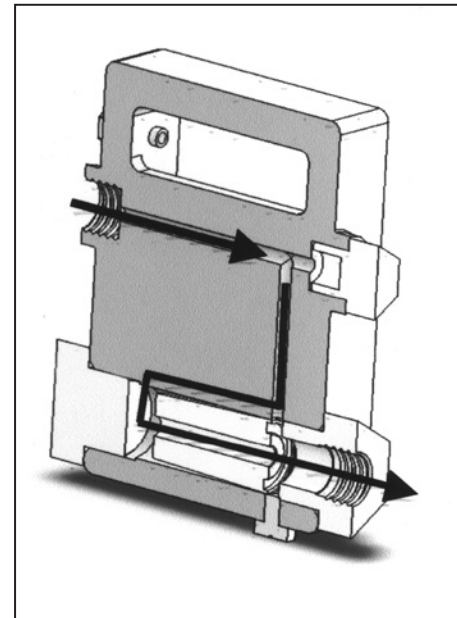

Flow Pattern

### Available types of LPT

LPT-1	28 to 500 bar (400 to 7250 PSI), without LED-display
LPT-4	28 to 500 bar (400 to 7250 PSI), with LED-display
LPT-7	3.4 to 83 bar (50 to 1200 PSI), without LED-display
LPT-8	3.4 to 83 bar (50 to 1200 PSI), with LED-display
LPT-9	1.4 to 13.8 bar (20 to 200 PSI), without LED-display
LPT-0	1.4 to 13.8 bar (20 to 200 PSI), with LED-display