

Ordering Codes: Laser Particle Counter LasPaC II-P (Portable) / LasPaC-II-M (Mobile)

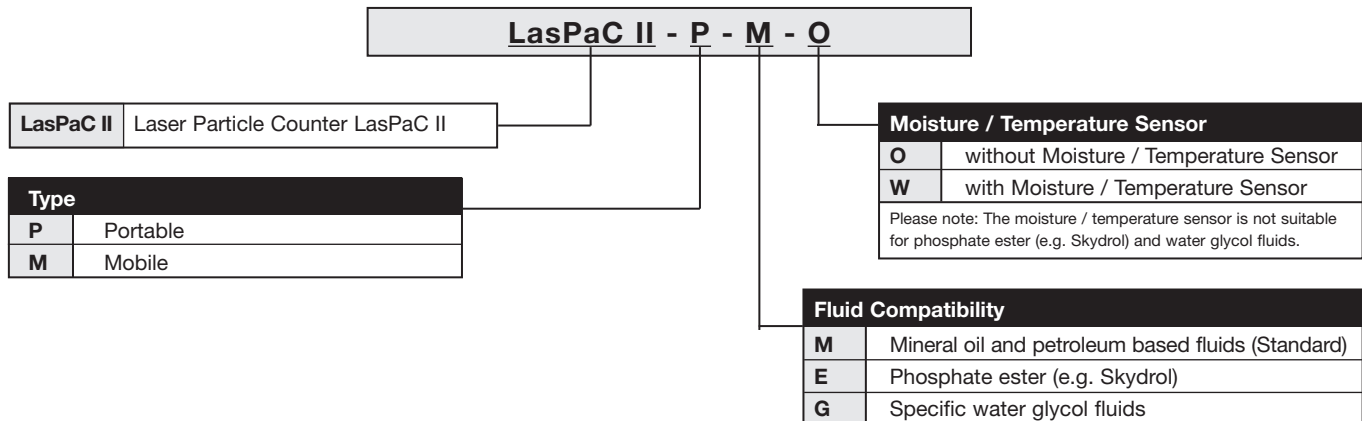

Ordering Codes: Bottle Sampling Unit for Laser Particle Counter LasPaC II

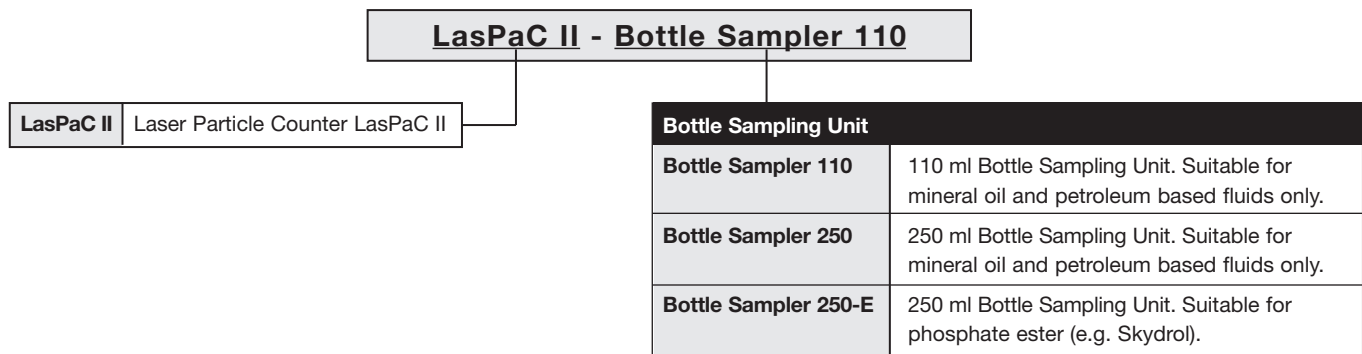

Ordering Codes: Laser Particle Counter LasPaC II-I (Inline)

