

## Angled, Bridge and Elongated Weld Plates, Safety Washers

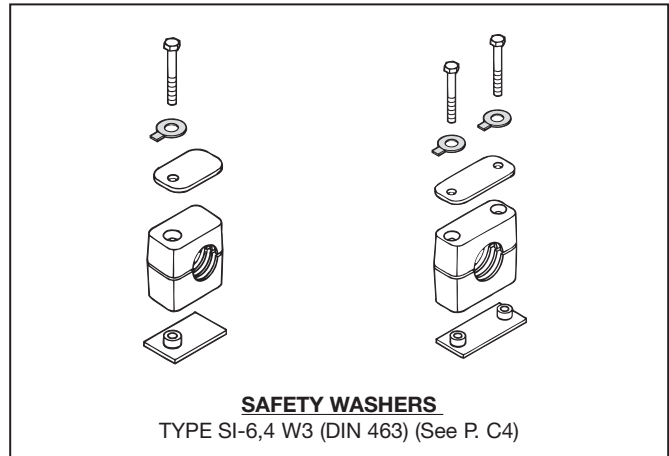

## Clamps For Proximity Switches and Electric Cables

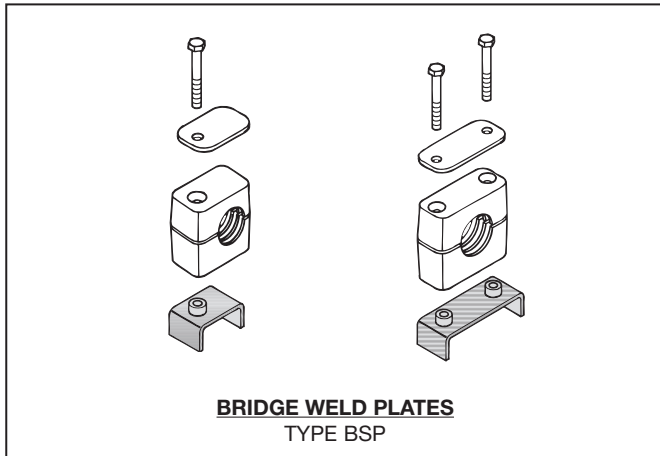
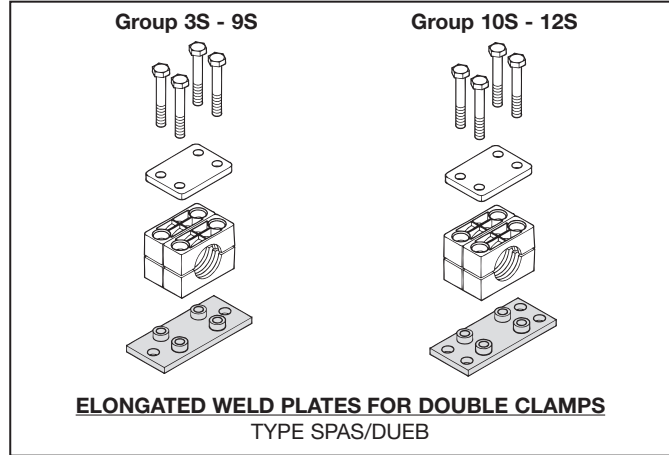
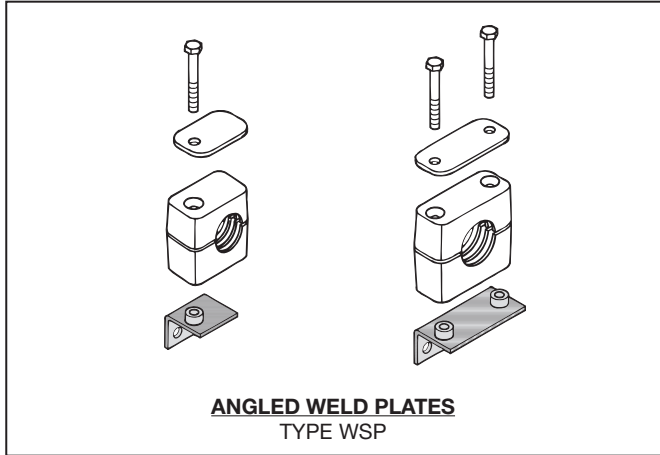
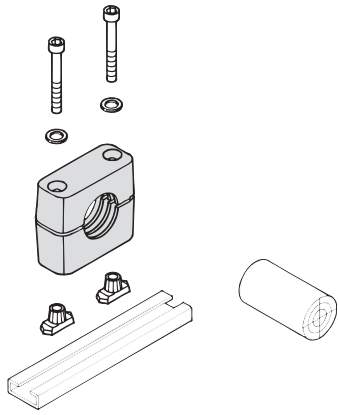

For proximity switches according to DIN EN 60947-5-2 or similar

Proximity switch – **round** construction, 30 mm diameter – fastened with a Group 4 Standard-Series clamp mounted on mounting rail with hexagon rail nuts. Loosening of the bolts provides **axial and horizontal position adjustment**.

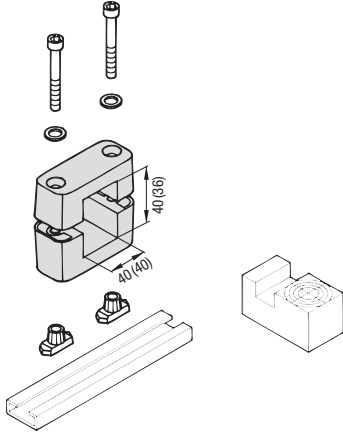

For proximity switches according to DIN EN 60947-5-2 or similar

Proximity switch – **rectangular** construction, 40 mm square – fastened with Group 5 Standard-Series clamp mounted on mounting rail with hexagon rail nuts. Loosening of the bolts provides **axial and horizontal position adjustment**.

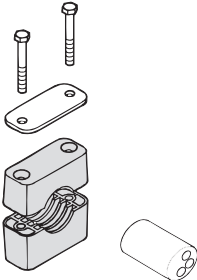

For clamping of electric cables:  
**STAUFF-Oval Clamps**

Group 6 Standard-Series for cable diameters between 20 and 50 mm.  
Group 6 S Heavy-Series for cable diameters between 40 and 72 mm.

Bolt types:  
Standard-Series: Hexagon Head Bolt in conjunction with cover plate. Socket Cap Screw with washer. Slotted Head Screw with washer.  
Heavy Series: Hexagon Head Bolt in conjunction with cover plate. For varying cable diameters only the bolt length needs to be varied.