

Specifications

- Stainless Steel Mesh 100 Mesh - 125 Micron
- Cast Iron Bushing
- Epoxy Bonded for Compatibility with most Petroleum & Mineral Based Fluids
- Perforated Steel Inner Supports
- Temperature to 250°F (120°C)



Options

- No By-Pass or 5 PSI By-Pass
- Custom Screens Available upon Request
- Custom Adaptors Available upon Request

Dimensions / Mounting Information

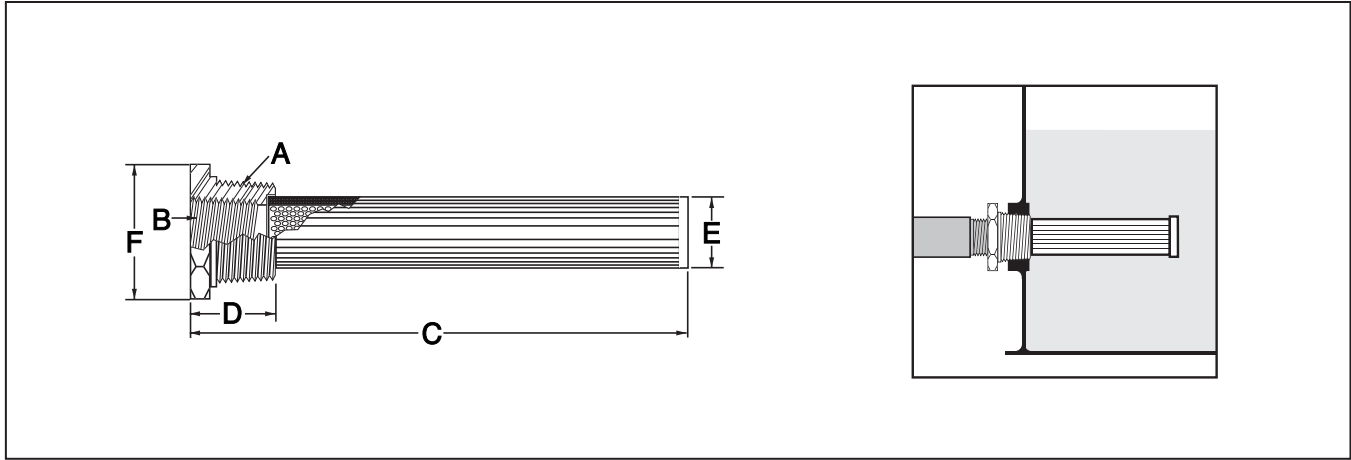

Ordering Information

| Part No. | Flowrate | | NPT Sizes | | C | | D | | Hex F | | E | | Screen Area | |
|-----------|----------|-----|-----------|--------|-----|------|----|-----|-------|-----|-----|-----|-----------------|-----------------|
| | gpm | lpm | A | B | mm | in | mm | in | mm | in | mm | in | cm ² | in ² |
| TMF-03-0 | 5 | 19 | 1" | 3/8" | 135 | 5.3 | 27 | 1.1 | 41 | 1.6 | 29 | 1.2 | 258 | 40 |
| TMF-05-0 | 5 | 19 | 1" | 1/2" | 135 | 5.3 | 27 | 1.1 | 41 | 1.6 | 29 | 1.2 | 258 | 40 |
| TMF-10-0 | 10 | 38 | 1 1/4" | 3/4" | 207 | 8.2 | 30 | 1.2 | 46 | 1.8 | 34 | 1.4 | 432 | 67 |
| TMF-15-0 | 15 | 57 | 1 1/2" | 1" | 208 | 8.2 | 31 | 1.2 | 55 | 2.2 | 42 | 1.7 | 554 | 86 |
| TMF-25-0 | 25 | 95 | 2" | 1 1/4" | 230 | 9.0 | 35 | 1.4 | 65 | 2.6 | 54 | 2.1 | 1025 | 159 |
| TMF-50-0 | 50 | 189 | 3" | 2" | 246 | 9.7 | 43 | 1.7 | 98 | 3.3 | 76 | 3.0 | 1625 | 252 |
| TMF-100-0 | 100 | 378 | 4" | 3" | 287 | 11.3 | 46 | 1.8 | 120 | 4.8 | 101 | 4.0 | 2032 | 315 |

By-Pass Option

| Part No. | Flowrate | | NPT Sizes | | C | | D | | Hex F | | E | | Screen Area | |
|-----------|----------|-----|-----------|--------|-----|------|----|-----|-------|-----|-----|-----|-----------------|-----------------|
| | gpm | lpm | A | B | mm | in | mm | in | mm | in | mm | in | cm ² | in ² |
| TMF-03-5 | 5 | 19 | 1" | 3/8" | 135 | 5.3 | 27 | 1.1 | 41 | 1.6 | 29 | 1.2 | 258 | 40 |
| TMF-05-5 | 5 | 19 | 1" | 1/2" | 135 | 5.3 | 27 | 1.1 | 41 | 1.6 | 29 | 1.2 | 258 | 40 |
| TMF-10-5 | 10 | 38 | 1 1/4" | 3/4" | 207 | 8.2 | 30 | 1.2 | 46 | 1.8 | 34 | 1.4 | 432 | 67 |
| TMF-15-5 | 15 | 57 | 1 1/2" | 1" | 208 | 8.2 | 31 | 1.2 | 55 | 2.2 | 42 | 1.7 | 554 | 86 |
| TMF-25-5 | 25 | 95 | 2" | 1 1/4" | 230 | 9.0 | 35 | 1.4 | 65 | 2.6 | 54 | 2.1 | 1025 | 159 |
| TMF-50-5 | 50 | 189 | 3" | 2" | 246 | 9.7 | 43 | 1.7 | 98 | 3.3 | 76 | 3.0 | 1625 | 252 |
| TMF-100-5 | 100 | 378 | 4" | 3" | 287 | 11.3 | 46 | 1.8 | 120 | 4.8 | 101 | 4.0 | 2032 | 315 |