

## Specifications

- Designed to seal suction lines passing through the top plate of reservoir
- Allows access for easy removal of suction elements for inspection and cleaning
- Includes top plate, bottom plate, gasket, rubber bushing and 4 x 5/16-18 thread forming screws
- Steel Plate
- Buna-N Seals

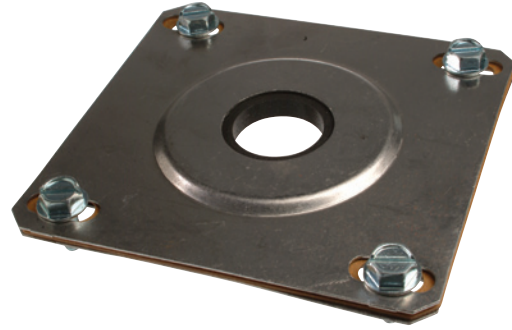

Part No.	SF-050	SF-075	SF-100	SF-125	SF-150	SF-200	SF-250	SF-300
Nominal Pipe Size	1/2"	3/4"	1"	1 1/4"	1 1/2"	2"	2 1/2"	3"

## Dimensions

Dimensions in inch (mm)

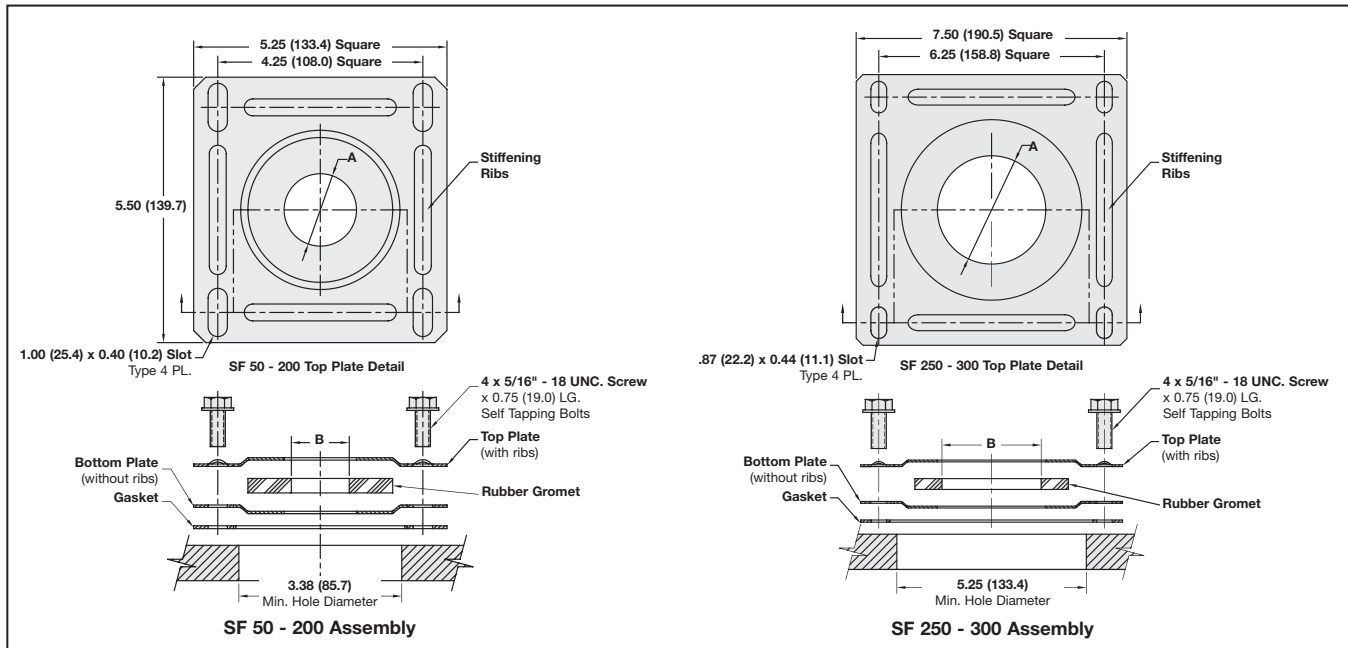

Part No.	A Dimension		B Dimension	
	mm	in	mm	in
SF-050	38	1 1/2	20	0.8
SF-075	38	1 1/2	25	1.0
SF-100	38	1 1/2	30	1.2
SF-125	51	2	41	1.6
SF-150	51	2	46	1.8
SF-200	64	2 1/2	58	2.3

Part No.	A Dimension		B Dimension	
	mm	in	mm	in
SF-250	76	3	70	2 3/4
SF-300	95	3 3/4	89	3 1/2