

Specifications

Combination air breather and water removal filter to handle flows up to 1500 l/min (395 US GPM)

Available in two types:

- SDB Series has a 3 micron absolute air filter. When saturated either the air filter or desiccant gel can be replaced as needed.
- SVDB Series has a 10 micron nominal filter. When saturated, the entire unit is replaced.
- Adaptor plates and fittings available for easy installation
- Z-R Desiccant gel is non toxic according to EC Council directive 88/379/EEC
- Available with active carbon for vapor filtration



When a reservoir or gearbox breathes, air containing water vapor is ingested into the system. Temperature fluctuations will cause this water vapor to condense. This condensed water will speed up the oxidation of the fluid and lead to damage in the system. The Stauff desiccant Air Breather first dries the air as it passed through the Z-R gel and then the dry air passes through a 3 micron synthetic media

element (SDB Series) to remove any solid contamination particles. As moisture is absorbed the gel will gradually change from red to orange. When the gel is orange, either replace the gel (SDB Series), or replace the entire unit (SVDB Series). An optional "filter minder" gives an indication of the status of the air breather.

SDB (series)

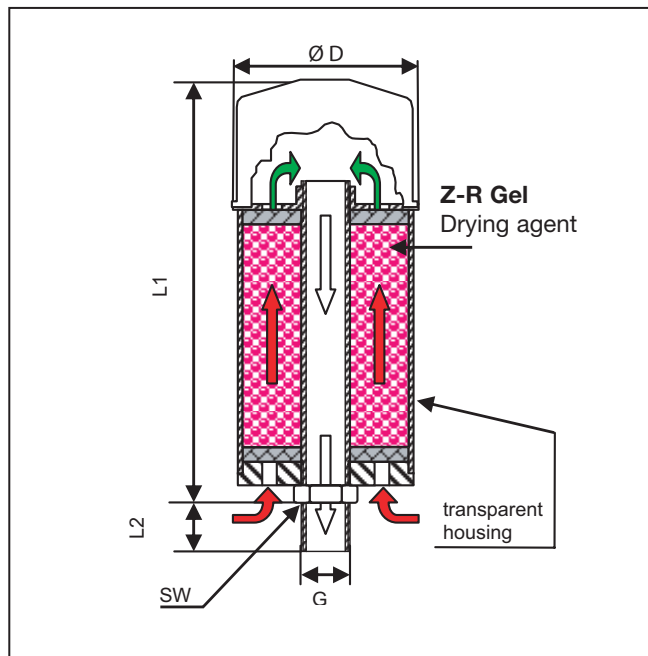

SVDB (series)

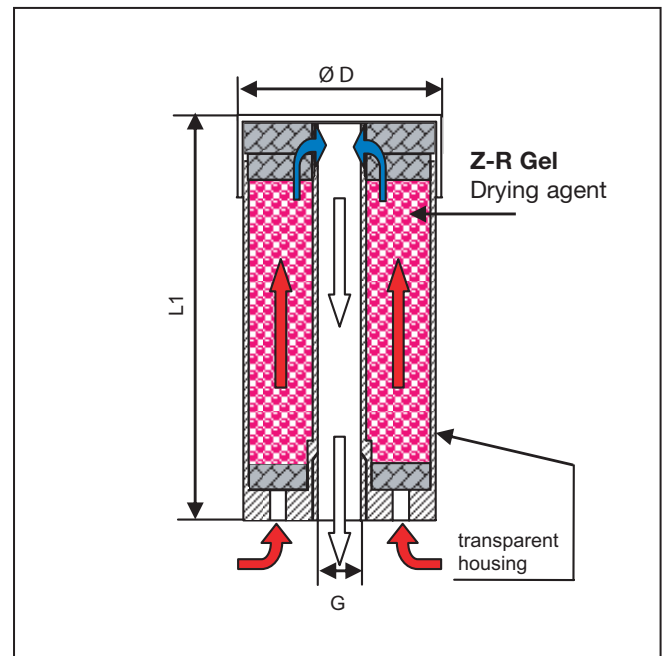

Technical Information

Part No.	D		L1		L2		G		SW		Max Flow Rate		Air Filter Micron Rating	Weight of Complete Unit		Desiccant Volume		Desiccant Weight		Max. Water Holding	
	mm	in	mm	in	mm	in	-	-	mm	in	l/min	US GPM	µm	g	lb	cc	in ³	g	lb	g	lb
SDB-093	100	3.9	160	6.3	20	0.79	G 3/4	male	32	1.26	700	185	3	1200	2.6	300	18.3	225	.5	86	.19
SDB-096	100	3.9	220	8.7	20	0.79	G 3/4	male	32	1.26	700	185	3	1500	3.3	600	36.6	450	1.0	172	.38
SDB-121	123.5	4.9	256	10.1	min ₂₅	1.0	G 1 1/4	male	50	1.97	1500	395	3	2700	6.0	1000	61.0	750	1.2	288	.63
SDB-122	123.5	4.9	366	14.4	min ₂₅	1.0	G 1 1/4	male	50	1.97	1500	395	3	4000	8.8	2000	122	1500	3.3	576	1.27
SVDB-093	94	3.7	109	4.3	-	-	G 3/4	female	-	-	700	185	10	220	0.5	300	18.3	225	.5	86	.19
SVDB-096	94	3.7	169	6.7	-	-	G 3/4	female	-	-	700	185	10	735	1.6	600	36.6	450	1.0	172	.38

AP Adaptor Plate for SDB (series)

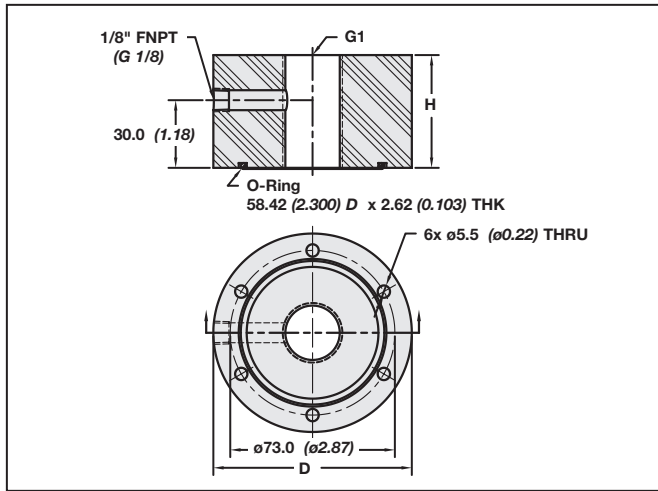

Dimensions in mm (inch)

Dimensions	D		H		G1
	mm	in	mm	in	
AP-1	88	3.46	50	1.97	G 3/4
AP-2	100	3.94	70	2.76	G 1- 1/4

AP adaptor plates and BA-5A adaptors allow the desiccant breathers to be mounted to existing connections. Plug, O-ring and socket head cap screws (DIN 912) are supplied with the AP.

Monitoring Moisture

Air Dryer - As moisture is absorbed the gel will gradually change from red to orange. When the gel is orange, either replace the gel (SDB Series), or replace the entire unit (SVDB Series).



Air Filter - The AP adaptor plate has a connection for the optional "filter minder" (FM-1) gives an indication of the status of the air breather. The unit can be reset when the element is changed.

Active Carbon

RMF Desiccant Air Breathers can be fitted with a combination of Z -R gel and active coal. The active coal will eliminate oil vapor and fumes. It will also prevent the oil vapor from contaminating the desiccant gel.

Spare Parts	
AP-1	Adaptor Plate for SDB-093/096
AP-2	Adaptor Plate for SDB-121/122
BA-5A	Adaptor fitting for SVDB-093/096
DBA-75	Adaptor fitting for SDB 93/96 for use with FM-1
FM-1	Contamination indicator for SDB series
RD-093	Replacement Gel for SDB-093
RD-096	Replacement Gel for SDB-096
RD-121	Replacement Gel for SDB-121
RD-122	Replacement Gel for SDB-122
SGB090-03-B	Replacement air filter for SDB-093/096
SGB120-03-B	Replacement air filter for SDB-121/122

BA-5A Adaptor for SVDB (series)

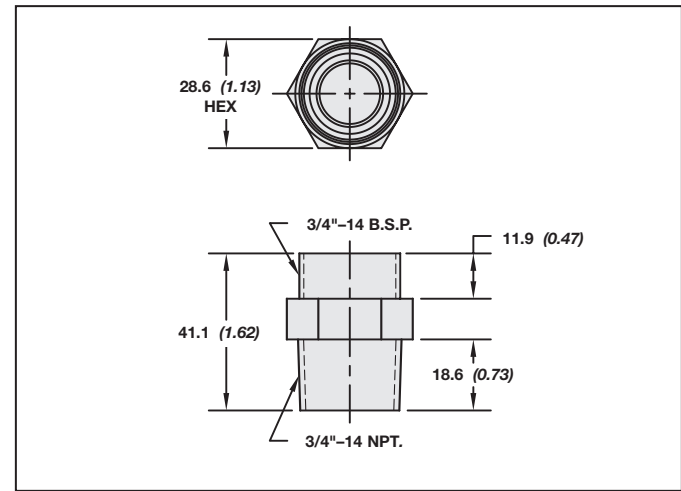

Dimensions in mm (inch)

Contamination Indicator FM

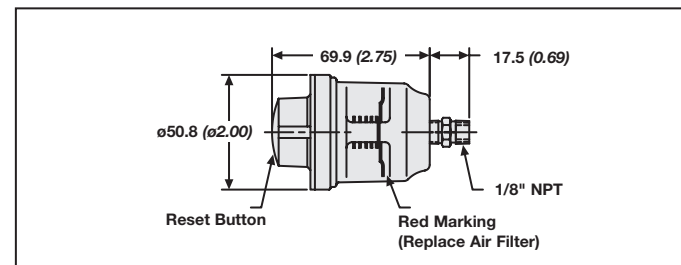

Dimensions in mm (inch)

Ordering Information

SDB - 122 - RC - AP - FM

Type	
SDB	Desiccant air breather
SVDB	Desiccant air breather (light series)

Size	
093	See page A23
096	
121	See page A23
122	

Options	
(None)	Standard
RC	Approximately 2/3 ZR Gel 1/3 Active Carbon, Available for SDB only

Adaptors	
(None)	Without adaptor
AP	With adaptor plate (SDB series)
BA	With BA-5A adaptor (SVDB series)

Contamination Indicator (In conjunction with AP only)	
(None)	Without contamination indicator
FM	visual contamination indicator